

GEARED MOTOR
MADE FOR
DIAMOND CORE DRILL
SPO - 14Ax - A

INSTRUCTION MANUAL

 WARNING

- © Read and understand this Instruction Manual carefully and completely for your own safety.
- © Save this Manual for future reference.



CONTENTS

1. WARNING AND CAUTION	
【1】 Safety Notice For Electric Tools	1
【2】 Notes For Usage Of Diamond Core Drill	3
【3】 For Mounting Geared Motor On Clamp And Pole Base	5
2. DESCRIPTION	6
3. SPECIFICATIONS	6
4. STANDARD ACCESSORIES	7
5. APPLICATIONS	7
6. GENERAL DRAWING AND SPECIFICATIONS IN OPERATION	7
7. OPERATIONAL INSTRUCTIONS	
【1】 Anchoring Diamond Core Drill	8
【2】 Anchoring Diamond Core Drill By Anchor Bolt	8
8. MAINTENANCE AND SERVICING	
【1】 Maintenance	10
【2】 Regular Servicing	10
9. FOR SERVICING	11
10. WARRANTY	11

1 . WARNING AND CAUTION

- ⊙ To avoid the risk of fire, electric shock and personal injury, follow all the instructions stated in "Safety Notice For Electric Tools" , "Notes For Usage Of Diamond Core Drill" and "For Mounting Geared Motor On Clamp And Pole Base".
- ⊙ Before use, read and understand this Manual, and follow all the safety instructions for your own safety.
- ⊙ Save the Manual for future reference.

【1】 Safety Notice For Electric Tools

WARNING

1. **Keep work area clean.**
 - ⊙ Cluttered work areas invite accidents.
2. **Avoid dangerous environments.**
 - ⊙ Do not use your Machine in rain, damp or wet locations.
 - ⊙ Keep work area well lit.
 - ⊙ Do not use your Machine in the presence of explosive or flammable gas or liquid.
3. **Guard against electric shock.**
 - ⊙ During use of electric tool, prevent body contact with grounded surfaces such as pipes or enclosures of air-conditions, microwave ovens or refrigerators.
4. **Keep bystanders and children away.**
 - ⊙ Never allow bystanders to contact tool or extension cord.
 - ⊙ Keep bystanders away at a safe distance from work area.
5. **Store idle tools securely.**
 - ⊙ When not in use, store tools in a dry secured place. Keep out of reach of children.
6. **Do not force tool.**
 - ⊙ Operate tool at a speed designed for it for optimum performance.
7. **Use right tool and right Accessories.**
 - ⊙ Do not force smaller tool and Accessories to do a job bigger than specified for them.
 - ⊙ Do not use your tool for other purposes than designed for it.
8. **Wear proper apparel.**
 - ⊙ Do not wear loose clothing or jewelry since these may be caught in moving parts.
 - ⊙ When working outdoors, wear rubber gloves and insulated no-skid footwear.
 - ⊙ Wear a protective hair covering to contain long hair.
9. **Use safety equipment.**
 - ⊙ Wear safety glasses. Use a dust mask for dusty operations.

⚠ WARNING

10. Do not abuse cord.

- ⊙ Never carry tool by its cord or disconnect it by yanking the cord from power receptacle.
- ⊙ Keep cord from heat, oil, sharp objects, cutting edges and moving parts.

11. Secure your work.

- ⊙ Use a clamp, vise or other proper means to secure the work so as to free both hands for better control of the Machine.

12. Do not overreach and maintain control.

- ⊙ Keep proper footing and balance at all times.

13. Maintain your Tool and Machine carefully.

- ⊙ For safe, efficient operation, maintain all cutting edges sharp.
- ⊙ Follow the instructions in this Manual for lubrication or replacement of Accessories.
- ⊙ Check Cord regularly. When damaged, contact its sales store or Consec's sales (service) representative for repairs or replacement.
- ⊙ When extension cord is used, check for damages regularly. If damaged, replace it.
- ⊙ Always keep Grip dry, clean and free from oil or grease.

14. Switch off and unplug your Machine in the following cases.

- ⊙ When not in use or before repairing.
- ⊙ Before replacing Accessories such as cutter, grinder or Bit.
- ⊙ When other hazardous situation could be anticipated.

15. Remove all Adjusting Keys, and Wrenches.

- ⊙ Before plugging your Machine, make certain all the Adjusting Keys and Wrenches, etc. used for adjustment are removed from the Machine.

16. Avoid accidental starting.

- ⊙ Do not carry a plugged-in tool with your finger on the switch.
- ⊙ Make sure tool switch is in OFF position before plugging in power cord.

17. Use proper extension cord suitable for outdoor use.

- ⊙ For outdoor use, use an extension cord such as cabtyre cord or cabtyre cable.

18. Stay alert.

- ⊙ During operation, carefully watch the proceedings, surroundings and how the situation stands to reduce risks.
- ⊙ Use common sense.
- ⊙ Do not use your Machine when you are tired or distracted.

19. Check parts for damages.

- ⊙ Before each use, check carefully Guards or other parts for damages to see that they should accomplish their designed function.
- ⊙ Check for alignment, binding of moving parts, parts damages, mounting, and any other conditions that may affect operation.

⚠ WARNING

- ⊙ For repairs or replacement of Guards or parts, follow the instructions of this Manual. Unless otherwise specified in the Manual, have them repaired or replaced by Consec's sales (service) representative. If Switch is damaged, have it replaced by Consec's sales (service) representative.
- ⊙ Do not use your Machine if its Switch does not turn it on or off.

20. Use recommended Accessories and attachment only.

- ⊙ Using tools and devices not recommended in this Manual or Consec catalog can lead to accidents and personal injuries.

21. Have your electric tool repaired by Consec's sales (service) representative.

- ⊙ This Machine is manufactured in compliance with applicable safety standards. Do not modify your Machine and Tool.
- ⊙ Have your Machine and Tool repaired by Consec's sales (service) representative. Repairs by unauthorized personnel may cause Machine failure, damages or personal injury.

【2】 Notes For Usage Of Diamond Core Drill

(In case of combination with Consec's original Clamp and Pole Base.)

⚠ WARNING

1. Check for embedded conduit etc.

- ⊙ Contact with live wiring during drilling can result in electric shocks.
- ⊙ Before drilling in a wall and floor, check for embedded conduit etc.

2. Do not use for overhead operation.

- ⊙ If the Machine is used for overhead operation, water used during operation can get into Motor and result in serious hazards. Never use this Machine for overhead operation.

3. Use special care when drilling through floors.

- ⊙ When drilling through floors, cores and water generally drop from Core Bit at completion of drilling. Before starting operation, make arrangement to provide for protection of all personnel and material below the area.

4. For operation at a high place, comply with the relevant laws and regulations to keep balance and control.

- ⊙ Keep balance and control on secured footing. Do not operate your Machine at a place higher than 1.5m from the footing.
- ⊙ For operation at a high place, set your Machine on a secured place.

5. Be sure to wear rubber gloves and rubber shoes.

- ⊙ Since water is used for operation, be sure to wear rubber gloves and rubber shoes during operation.

⚠ WARNING

6. Use a power source provided with earth leakage breaker.
7. Use your Machine at the Nameplate voltage.
 - ⊙ Use of supply voltage higher than specified will cause Machine speed exceedingly high and can lead to damages and injuries.
8. Secure Pole Base properly.
 - ⊙ It is very important to anchor Pole Base securely on the work surface. Unsecured anchoring may cause rattling of Core Drill, fracturing Diamond Core Bit. Bit may also jam in hole and be damaged.
9. Be sure to use Water Collector.
 - ⊙ Be sure to use Water Collector to prevent spattered water from getting into Motor during operation.
 - ⊙ Install Water Collector securely for complete water trapping and drainage.
10. Prevent body contact with rotating Core Bit and Main Shaft.
 - ⊙ Keep away from rotating Core Bit and Main Shaft, which could invite serious injury.
11. Keep Motor Vents clear to assure proper Motor ventilation.
12. When any irregularity is found, turn Switch off immediately.
 - ⊙ If Core Bit comes to a stall or irregular noises are heard during operation, turn Switch off immediately.
13. Tighten Knob Bolt and secure Drill Head before releasing hand from Feeding Handle.
14. When loosening Knob Bolt, hold firm grip of Feeding Handle to prevent Drill Head from moving.

⚠ CAUTION

1. Make proper Clamp adjustment.
 - ⊙ Make Clamp adjustment not to allow a play between Pole Base and Clamp. Follow the instructions in "2. Checking and Adjustment of Clamp".
2. Apply grease on Core Bit Attaching Screw.
 - ⊙ Apply grease on Core Bit Attaching Screw before attaching Core Bit onto Main Shaft. This will make it easy to remove Bit after operation.
3. Keep feeding water during entire drilling operation.
 - ⊙ Overheating of Core Bit reduces not only drilling performance but also its life. So be sure to keep feeding water during entire drilling operation.
 - ⊙ Use clear water only. Use of waste water recycling may lead to Machine failure.
4. Turn Switch on and wait until Core Bit speed increases to the full, and then start drilling.
 - ⊙ Wait until Core Bit speed increases to the full, and then start drilling.

⚠ CAUTION

5. Do not turn Motor on with Core Bit resting on the work surface.
 - Ⓞ Such mishandling can cause fracturing of Core Bit Crown or failure of Core Drill.
6. Avoid sudden stop of rotation or locking of Core Bit in the course of drilling.
 - Ⓞ This can cause fracturing of Core Bit Crown (segment) or failure of Core Drill.

【3】 For Mounting Geared Motor On Clamp And Pole Base.

⚠ WARNING

1. This Geared Motor is designed to be combined with Clamp and Pole Base designed for Core Drill. Use Geared Motor in one of the following ways.
 - Ⓞ To combine with a genuine "HAKKEN" brand Clamp and Pole Base.
2. Clamp and Pole Base which Geared Motor is mounted must have capacity of specified Max.drilling diameter or larger capacity.
 - Ⓞ If combined with Clamp and Pole Base which have lesser capacity, Geared Motor can not function fully and this could lead to accidents and injuries.
3. Combine Geared Motor with Clamp securely.
 - Ⓞ Attach Key always.
 - Ⓞ Properly fix them by using 4 pcs of Attaching Bolts.

2 . DESCRIPTION

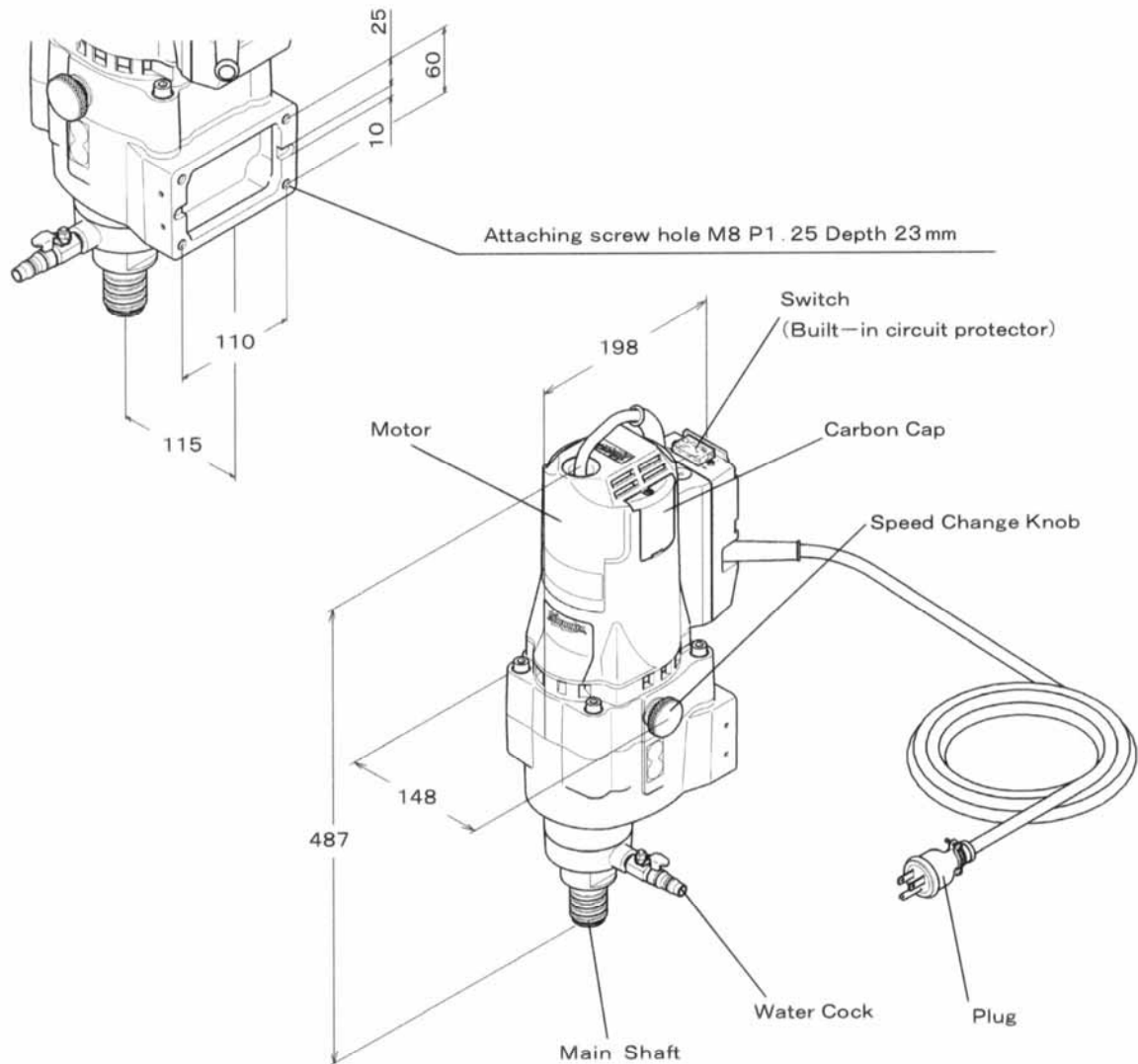

3 . SPECIFICATIONS

Model	SPO-14Ax-A
Motor	Single phase series commutator motor
Power Supply	230 V ~ 50/60 Hz
Rated Current	10.4 A
Max. Output	3400 W
No Load Speed	300/700 min ⁻¹
Max. Bit Dia.	355mm (14")
Core Bit Installing Screw	A Rod Screw
Geared Motor Weight	12.8 kg (Excluding cord)

4 . STANDARD ACCESSORIES

© Instruction Manual 1

5 . APPLICATIONS

This tool is Geared Motor made for Core Drill for drilling in concrete.

- © Core drilling in concrete for road, dam, tunnel and bridge construction
- © Sampling test pieces
- © Core drilling of pilot hole for guard rail post and fence post
- © Core drilling in concrete for wiring and plumbing for air conditioning, telephone, electricity, water and gas supply

6 . GENERAL DRAWING AND SPECIFICATIONS IN OPERATION

© Example of Geared Motor is mounted on □ 59 Clamp C L -591
and □ 59 Pole Base SB-591-1000

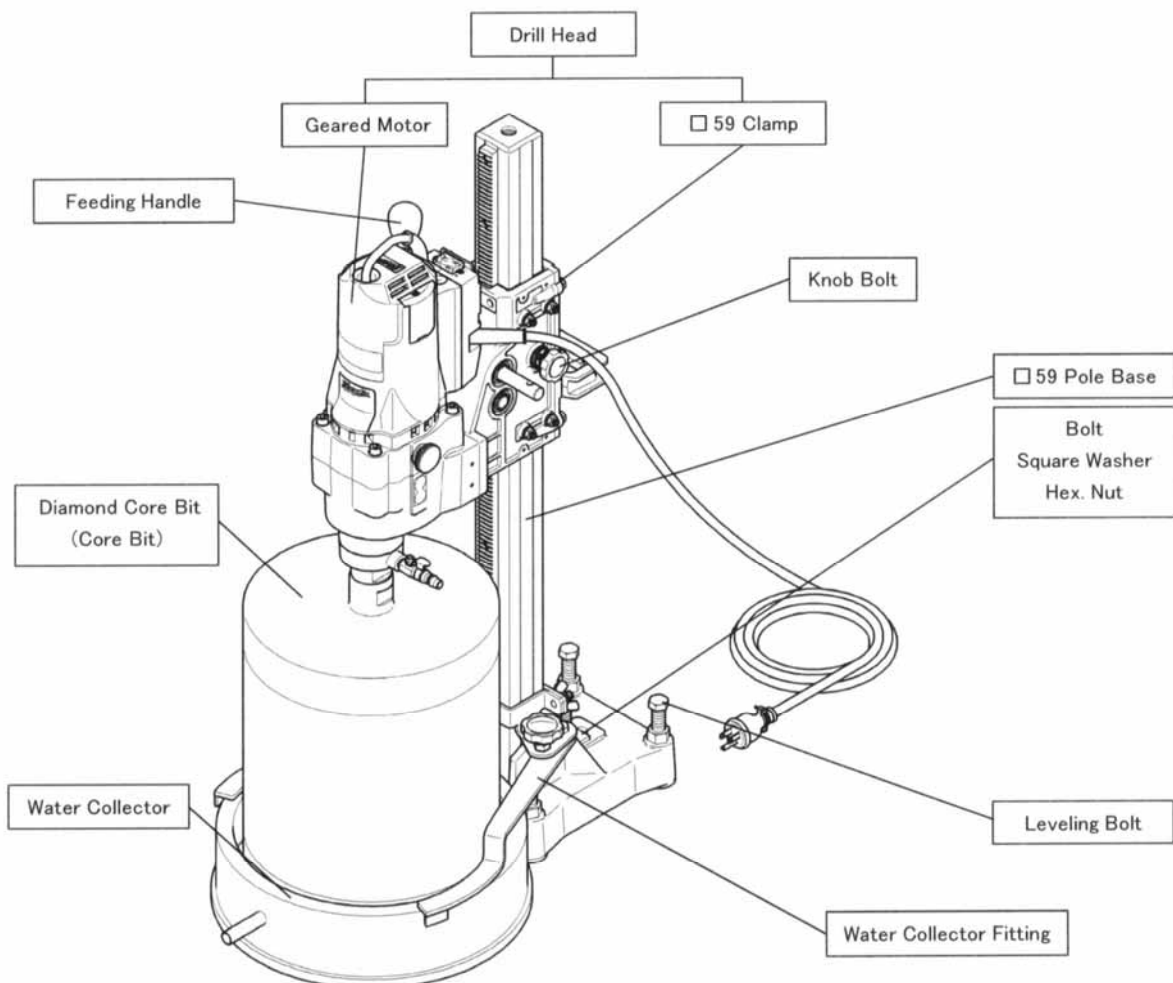

7 . OPERATIONAL INSTRUCTIONS

(Explanation referring to general drawing during operation.)

【1】 Anchoring Diamond Core Drill

- ◎ Core Drill can be anchored by means of Anchor Bolt, Vacuum Pad or Support Jack. Follow the below procedures for Bolt Anchor Method.

【2】 Anchoring Diamond Core Drill By Anchor Bolt

1. Installation of Anchor Bolt

- 1) Drill Anchor Bolt hole, using a Hammer drill.
- 2) Set Anchor Bolt (W1/2) into the hole.

2. Installation of Diamond Core Drill

- 1) Screw Bolt (W1/2) into Anchor Bolt.
- 2) Insert Bolt (W1/2) into the slot of Pole Base and fasten Square Washer and Hex. Nut (W1/2).
- 3) Install Drill Head onto Pole.
- 4) Adjust the position of Pole Base so as to align Main Shaft with the hole to be drilled.
- 5) Adjust leveling with Leveling Bolts so as to eliminate rattling of Pole Base. After completion of adjustment, secure Leveling Bolt with Wing Nut.
- 6) Tighten Hex. Nut (W1/2) to secure Pole Base.
- 7) Set desired rotating speed with Speed Change Knob.

3. Installation of Diamond Core Bit

- ◎ Thread Core Bit onto Main Shaft.

4. Installation of Water Collector

- ◎ Secure Water Collector with Water Collector Fitting.

▲ WARNING : Be sure to use Water Collector to prevent spattered water from getting into Motor during operation.

5. Arrangement for water disposal

- ◎ Receive water into a bucket by connecting a hose with Drain Port of Water Collector or suck water through Drain Port using a Vacuum Cleaner.

6. Arrangement for water supply

- ◎ Connect a hose between a water source and Water Cock using hose coupler.

▲ WARNING : Do not stop water feeding during operation.

7. Core drilling

⚠ WARNING : When drilling a through-hole, take proper measures to provide for protection on the other side where Core Bit penetrates.

1) Turn Switch off and plug in.

⚠ WARNING : To prevent accidental starting, make certain that Motor Switch is in OFF position before plugging your Machine.

2) Turn on a water tap and open Water Cock slowly, adjusting water flow.

⚠ CAUTION : Allow water to flow at about 2L per minute.

3) Turn Switch on to drill with Feeding Handle. Start drilling by turning Feeding Handle slowly until Core Bit comes in light contact with work surface. While starting to drill, apply light pressure on Feeding Handle until Drill Bit Penetrates to 5–10mm depth. Then keep drilling under uniform pressure.

⚠ WARNING :

1. If Motor is switched on with Bit resting on the work surface, it causes Core Bit fracturing or Core Drill failure, resulting in hazardous accidents.
2. Wait until the rotation of Core Bit increases to the full and then start drilling.
3. Since Drill Bit often wanders at the starting, turn Feeding Handle slowly applying light pressure to prevent Bit wandering. Allow water to flow at about 2L per minute.

8. After completion of drilling

- 1) Remove water hose and Water Collector.
- 2) Remove Core Bit.
- 3) Remove Drill Head from Pole Base.
- 4) Loosen Hex. Nut and dismount Pole Base.

8 . MAINTENANCE AND SERVICING

【1】 Maintenance

- 1) Clean and maintain your Machine after each use.

The enclosure of Drill Head is of aluminum in Gear Case portion and of rugged synthetic resin in Motor portion. Gasoline, thinner, petroleum or kerosene damages the surface of Motor enclosure. Use dry cloth or cloth soaked in soapy water for cleaning Motor enclosure.

- 2) Maintenance for Motor.

After entire operation is over, secure Drill Head onto Pole Base, run Motor with non-load and drive dirt and dust out of Motor interior.

【2】 Regular Servicing

1. Checking of Carbon Brush

- 1) How to check

Remove Brush Cover using Flat-tipped Screw Driver etc., and take Carbon Brush out. After replacement, secure Brush Cover.

- 2) Replacement

- The excessive abrasion of Carbon Brushes causes Motor failure. Check regularly, when they are worn up to the wear limit line (6mm), replace with new ones.
- Keep them clean for free sliding in Brush Tube.

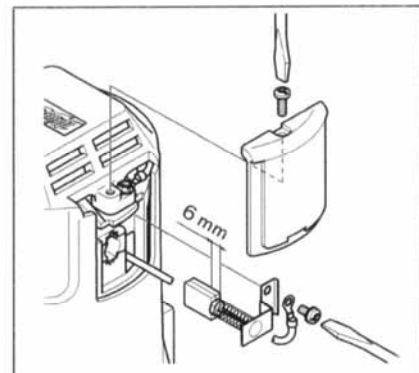

▲ CAUTION : Insist on identical Carbon Brushes in replacement.

2. Checking and Adjustment of Clamp

(In case of combination with □ 59 clamp CL-591.)

- ◎ Set Drill Head onto Pole Base. While moving Feeding Handle, tighten 8 pieces of Hex. Socket Set Screws on Clamp in good balance with Hex. Bar Wrench and adjust the gap between Pole and Clamp.

▲ CAUTION

If Hex.Socket Set Screws are fastened too tight, Feeding Handle gets heavy. When Slide Plate is worn and starts to rattle, replace it.

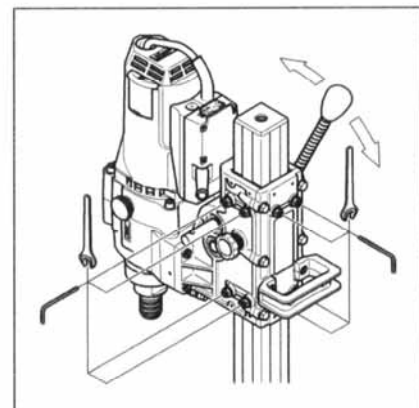

9 . FOR SERVICING

© For servicing your Machine, contact Consec's Authorized representative.

10 . WARRANTY

We will guarantee the HAKKEN core drilling machine for 6 months from the date of delivery. During this period we will rectify material and production defects free of charge. We are not responsible for any other damage direct nor indirect other than this. This warranty does not cover normal wear and tear, overloading, non-compliance with the operating instructions and intervention by unauthorized persons or the use of parts from other companies.



CONSEC CORPORATION

Main office : 4-6-8 Shoko Center Nishi-ku Hiroshima 733-0833 Japan

International Department : 4-6-8 Shoko Center Nishi-ku Hiroshima 733-0833 Japan

Phone : 81-82-276-3231

Fax : 81-82-276-3239

E0141-0 / SPO-14Ax-A (B5)