



DIAMOND WALL CUTTER
CDW - 40AEx

INSTRUCTION MANUAL

- © Thank you for purchasing our products.
- © Before using, please read instruction manual carefully, and use the machine safety by following the instructions.
- © After reading, please keep it where anyone can utilize.

CONSEC CORPORATION

MEANING OF SIGNAL WORDS ⚠WARNING & ⚠CAUTION

The instruction manual includes three signal words ; ⚠WARNING & ⚠CAUTION which mean as follows.

⚠WARNING : It is assumed that if the user use the machine wrongly, it would be the risks that the user could be died or injured.

⚠CAUTION : It is assumed that if the user use the machine wrongly, it would be the risks that the user could remain the disabled or damage for the materials.

POINT : Important notices for the installation of machine, instructions, maintenance and servicing.

“CAUTION” might cause the serious accidents depending on the situations. Since we mention the important notices, please strictly follow the instruction in order to avoid the accidents.

CONTENTS

1. WARNING AND CAUTION	
【1】 Safety Notice for Electric Tools	2
【2】 Notes for Usage Of Wall Cutter	4
2. DESCRIPTION	6
3. SPECIFICATIONS	7
4. STANDARD ACCESSORIES	7
5. APPLICATIONS	8
6. OPTIONS (SEPARATELY SOLD)	8
7. GENERAL DRAWING IN USE AND SPECIFICATIONS	
【1】 CDW-40AEx for 30" use	10
【2】 Specifications for the use with CDW double line cut attachment	12
8. OPERATIONAL INSTRUCTIONS FOR CONTROL BOX BE-31A	
【1】 Control Panel of Control Box BE-31A(230V type)	13
【2】 Operational Instructions for Wall Cutter CDW-40AEx using Control Box BE-31A	13
9. OPERATIONAL INSTRUCTIONS	
【1】 Anchor Fixing	15
【2】 Installation of Wall Cutter	15
【3】 Setting Speed of Geared Motor	16
【4】 Installation of Diamond Blade	16
【5】 Connection of Control Box BE-31A	17
【6】 Connecting Track Rails	17
【7】 Installation of Blade Cover	18
【8】 Preparation of feeding water	18
【9】 Treatment of splashing water	18
【10】 Cutting Operation for Automatic Feeding	19
【11】 Detachment of Wall Cutter	21
10. SEPARATION AND ASSEMBLING OF WALL CUTTER	
【1】 Separation of Wall Cutter	22
【2】 Assembling of Wall Cutter	22
11. INSTALLATION AND DETACHMENT OF DIAMOND BLADE	
【1】 Installation of Diamond Blade	23
【2】 Detachment of Diamond Blade	23
12. TROUBLESHOOTING DURING OPERATION	
【1】 The troubles could occur during operation and their solution	24
【2】 An example of solving method when Diamond Blade is locked	25
13. MAINTENANCE AND SERVICING	
【1】 Maintenance	25
【2】 Regular Inspection, Servicing	25
【3】 Repairs	26
【4】 Regular Servicing	26
14. WARRANTY	27

1 . WARNING AND CAUTION

- ⊙ To avoid the risk of fire, electric shock and personal injury, follow all the instructions stated in "Safety Notice for Electric Tools" , "Notes For Usage of Wall Cutter".
- ⊙ Before use, read and understand this manual, and follow all the safety instructions for your own safety.
- ⊙ After reading, save the manual in that anyone can utilize as for the reference.

【1】 Safety Notice for Electric Tools

WARNING

1. Do not use for other than specified purposes.
2. Keep bystanders away at a safe distance from work area.
 - ⊙ Never allow bystanders to contact tool or extension cord.
3. Avoid dangerous environments.
 - ⊙ Do not use electric tools itself or control panel in rain, damp or wet locations.
 - ⊙ Keep work area well lit.
 - ⊙ Do not use your machine in the presence of explosive or flammable gas or liquid.
 - ⊙ Cluttered work areas invite accidents.
4. Wear proper apparel.
 - ⊙ Do not wear loose clothing or jewelry since these may be caught in moving parts.
 - ⊙ When working outdoors, wear rubber gloves and insulated no-skid footwear.
 - ⊙ Wear a protective hair covering to contain long hair.
5. Wear safety glasses.
 - ⊙ When working, wear safety glasses. Use a dust mask for dusty operations.
6. Do not overreach and maintain control.
 - ⊙ Keep proper footing and balance at all times.
7. Stay alert.
 - ⊙ Do not come close to the rotating parts. Doing so could get entangled in it or could get injured.
 - ⊙ During operation, carefully watch the proceedings, surroundings and how the situation stands to reduce risks.
 - ⊙ Use common sense.
 - ⊙ Do not use your machine when you are tired or distracted.
8. Guard against electric shock
 - ⊙ During use of electric tool, prevent body contact with grounded surfaces such as pipes or enclosures of air-conditions, microwave ovens or refrigerators.
 - ⊙ Use power source equipped with earth leakage breaker.

⚠ WARNING

9. **Do not abuse cord.**
 - ⊙ Never carry tool by its cord.
 - ⊙ Never disconnect it by yanking the cord from power receptacle.
 - ⊙ Keep cord from heat, oil, sharp objects, cutting edges and moving parts.
10. **Use recommended accessories and attachment only.**
 - ⊙ Using tools and devices not recommended in this manual or CONSEC catalog can lead to accidents and personal injuries.
11. **Check parts for damages.**
 - ⊙ Before each use, check carefully guards or other parts for damages to see that they should accomplish their designed function.
 - ⊙ Check for alignment, binding of moving parts, parts damages, mounting, and any other conditions that may affect operation.
 - ⊙ For repairs or replacement of guards or parts, follow the instruction of this manual.
 - ⊙ Unless otherwise specified in the manual, have them repaired or replaced by CONSEC's sales (service) representative.
 - ⊙ Do not use your machine if its switch does not turn it on or off.
 - ⊙ If Switch is damaged, have it replaced by CONSEC's sales (service) representative.
12. **Switch off and unplug your machine in the following cases.**
 - ⊙ When not in use or before repairing.
 - ⊙ Before replacing accessories such as cutter, grinder or Bit.
 - ⊙ When other hazardous situation could be anticipated.
13. **Remove all adjusting keys, and wrenches.**
 - ⊙ Before plugging your machine, make certain all the adjusting keys and wrenches, etc. used for adjustment are removed from the machine.
14. **Maintain your tool and machine carefully.**
 - ⊙ Follow the instructions in this manual for replacement of accessories.
 - ⊙ Always keep grip dry, clean and free from oil or grease.
 - ⊙ Check cord regularly. When damaged, contact its sales store or CONSEC's sales (service) representative for repairs or replacement.
 - ⊙ When extension cord is used, check for damages regularly. If damaged, replace it.
15. **Store idle tools securely.**
 - ⊙ When not in use, store tools in a dry secured place. Keep out of reach of children.
16. **Avoid accidental starting.**
 - ⊙ Do not carry a plugged-in tool with your finger on the switch.
 - ⊙ Make sure tool switch is in OFF position before plugging in power cord.
17. **Use proper extension cord suitable for outdoor use.**
 - ⊙ For outdoor use, use an extension cord such as cabtyre cord or cabtyre cable.
18. **Use right tool and right accessories.**
 - ⊙ Do not force smaller tool and accessories to do a job bigger than specified for them.

⚠ WARNING

19. Have your electric tool repaired by CONSEC's sales (service) representative.
- ⊙ This machine is manufactured in compliance with applicable safety standards. Do not modify your machine and Tool.
 - ⊙ Repairs by unauthorized personnel may cause machine failure, damages or personal injury.
 - ⊙ Have your machine and tool repaired by CONSEC's sales (service) representative.

[2] Notes for Usage of Wall Cutter

⚠ WARNING

1. Check for embedded conduit etc.
 - ⊙ Contact with live wiring during cutting can result in electric shocks.
 - ⊙ Before cutting on a wall and floor, check for embedded conduit etc.
2. Do not install main motor downward in horizontal cutting.
 - ⊙ Wall cutter always use water. If main motor is installed downward in horizontal cutting, water may enter the motor or water accumulate inside of blade cover. This is very dangerous. Do not use wall cutter in the way main motor facing downward.
3. During cutting operation, if cutting water fall over main motor and feed motor, stop the operation immediately. Take preventive measures against falling water.
4. Pay attention to the safety where diamond blade penetrates.
 - ⊙ On the opposite side where diamond blade penetrates is very dangerous. Cutting water may be scattered when diamond blade penetrates. To prevent any damage to the person or object, take necessary measures for safeguard and disposal before starting an operation.
5. For operation at a high place, comply with the relevant laws and regulations to keep balance and control.
 - ⊙ In case of wall cutting, mounting and removing of wall cutter main body must be done at lower position.
 - ⊙ In case of wall cutting, falling of wall cutter main body is very dangerous. Take necessary measures to prevent it.
 - ⊙ For operation at a high place, set your machine on a secured place.
6. Be sure to wear rubber gloves and rubber shoes.
 - ⊙ Since water is used for operation, be sure to wear rubber gloves and rubber shoes during operation.
7. Use a power source provided with earth leakage breaker.
8. Use your machine at the nameplate voltage.
 - ⊙ Use of supply voltage higher than specified will cause machine speed exceedingly high and can lead to damages and injuries.
9. Anchor the track rail securely.
 - ⊙ If the track rail is not anchored securely, it could hamper normal operation and be very hazardous.

⚠ WARNING

10. When attaching wall cutter main body on the track rail, insert it in the correct direction. When detaching it, pull it in the opposite direction.
 - ⊙ In case of cutting the wall, when feeding gear of wall cutter is disengaged from rack gear of track rail, be aware that wall cutter main body could fall down.
11. Carry out cutting operation with the blade cover installed.
12. Never touch a running diamond blade.
 - ⊙ Keep yourself away from a running diamond blade. It is very hazardous, causing injury and accidents.
13. Keep motor vents clear to assure proper motor ventilation.
14. When any irregularity is found, turn switch off immediately.
 - ⊙ If diamond blade comes to a stall or irregular noises are heard during operation, turn switch off immediately.
15. Be careful with falling concrete block or debris where wall cutter is used.
 - ⊙ In the case of opening cut on the wall or floor, take necessary measures to prevent separated concrete block from falling off, such as fixing by chain hoist, before starting an operation.

⚠ CAUTION

1. For the installation at cutting place, first track rails should be installed. Then wall cutter should be mounted on rails.
 - ⊙ For horizontal cutting in a wall, install track rails in such a manner that main motor should face upward and diamond blade downward.
2. Adjust level of track rail.
 - ⊙ Leveling should be adjusted by moving ten hex. socket head set screws on track rail using hex. bar wrench 5mm up and down. When more than 2 pcs of track rails are connected, leveling should be adjusted so that track rails should not be deformed or dislocated at the junctures.
3. Be sure to use diamond blade.
 - ⊙ This Machine is especially designed for use with a diamond blade. Do not use tools other than a diamond blade.
4. Keep feeding water during entire cutting operation.
 - ⊙ Overheating of diamond blade reduces not only cutting performance but also its life. So be sure to keep feeding water during entire cutting operation.
 - ⊙ Use clear water only. Use of waste water recycling may lead to machine failure.
5. Do not turn the switch on with diamond blade resting on the cutting surface.
 - ⊙ This could cause a damage to diamond blade and wall cutter.
6. Turn Switch on and wait until diamond blade speed increases to the full, and then start cutting.
 - ⊙ Wait until diamond blade speed increases to the full, and then start cutting.

⚠ CAUTION

7. If depth of one cutting is big, this not only force the machine too much, but slow the cutting speed. Avoid forced cutting.
8. Cutting shall be done in the correct direction (Upper cut) as much as possible.
 - ⊙ For the cutting in opposite direction (Down cut), the force is applied by running blade in the moving direction and the movement on track rails may not be stable. As a result cutting performance may decrease.
9. Do not stop the machine suddenly while cutting. Also do not lock a diamond blade.
 - ⊙ Tip of diamond blade or wall cutter main body could be damaged.

2 . DESCRIPTION

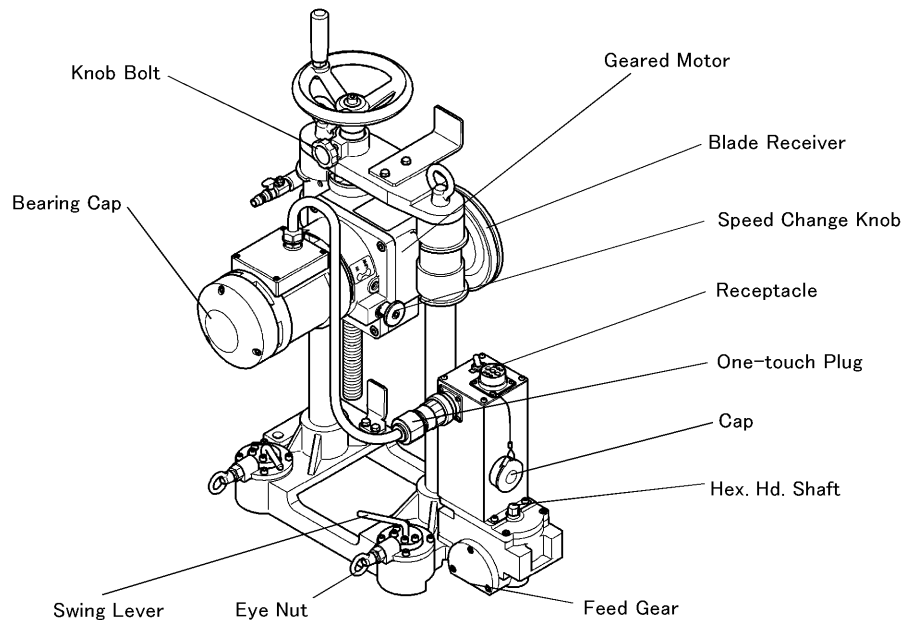
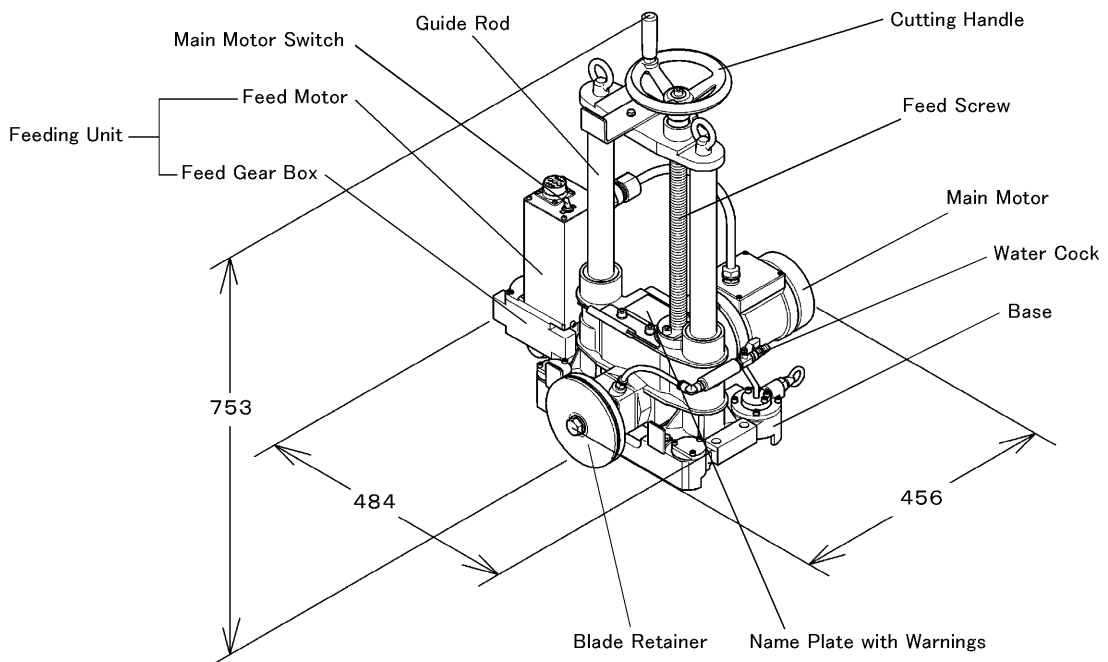

3 . SPECIFICATIONS

Model		CDW-40AEx
Main Motor	Motor	Single phase series commutator motor
	Power Supply	Single-phase A.C. 230V 50/60Hz
	Rated Current	15.8 A
	Normal Output	2400 W
	No Load Speed	840/340 min ⁻¹ (HI / LOW)
Feed Motor	Motor	DC motor (magnet Type)
	Normal Output	54 W
Rated Feeding Speed		632 mm/min
Rated Feeding Thrust		1785 N
Maximum Blade Dia.		1038 mm (40")
Blade Hole Dia.		35 mm
Max. Depth of Cut	784mm(30")	312.5mm (if new blade is used.)
	1038mm(40")	439.5mm (if new blade is used.)
Weight (Excluding cord)		36.5 kg
Weight		37.5 kg

4 . STANDARD ACCESSORIES

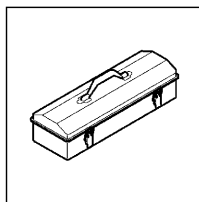

Tool Box
Y-455
... 1 pce

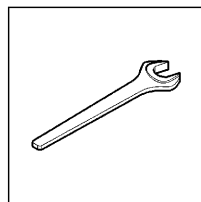

Single-ended Wrench
24mm
... 1 pce

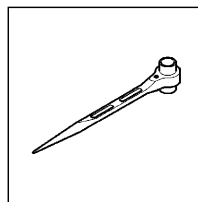

Ratchet Wrench
14 x 17mm
... 1 pce

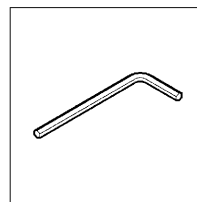

Hex. Bar Wrench
5, 6mm
... 1 pce each

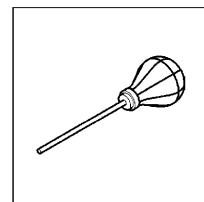

Dust Blower
... 1 pce

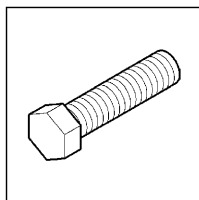

Hex. Hd. Bolt
W3/8 x 38mm
... 8 pcs

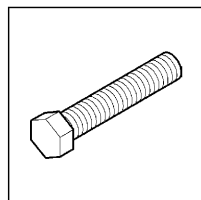

Hex. Hd. Bolt
W3/8 x 50mm
... 8 pcs

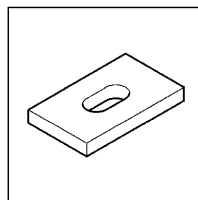

Square Washer
W3/8 x 50 x 30 x t6
... 8 pcs

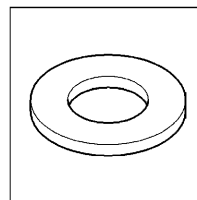

Flat Washer
W3/8
... 8 pcs

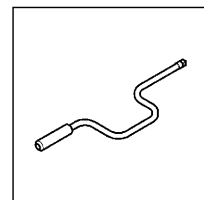

Speeder
204
... 1 pce

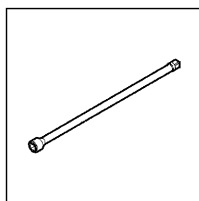

Extension Bar
307
... 1 pce

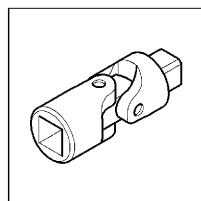

Universal Joint
208
... 1 pce

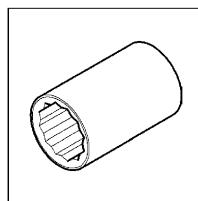

Socket
3D-13mm
... 1 pce

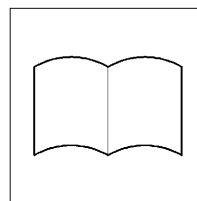

Instruction Manual
... 1 pce

5 . APPLICATIONS

- © Cutting on floor or (flat) wall of reinforced concrete structure
(e.g. Making aperture on reinforced concrete structure)

6 . OPTIONS (SEPARATELY SOLD)

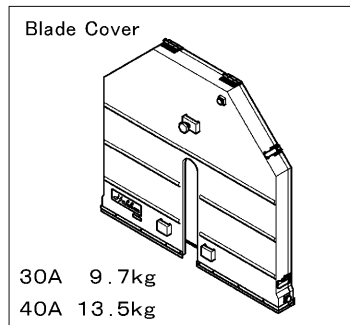

Blade Cover for CDW-40AEx
30" type and 40" type are available.

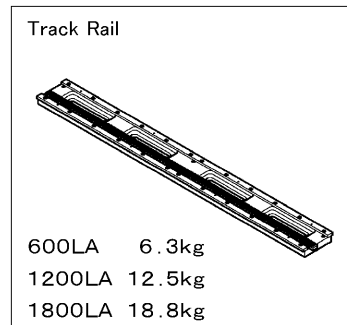

Track Rail for CDW-40AEx
600L, 1200L, 1800L are available.

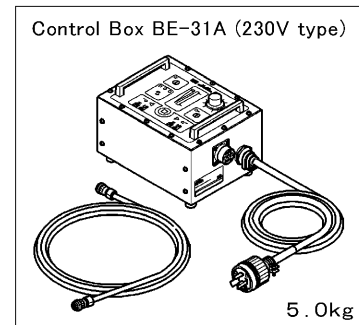

This is connected with Wall Cutter and controls it.

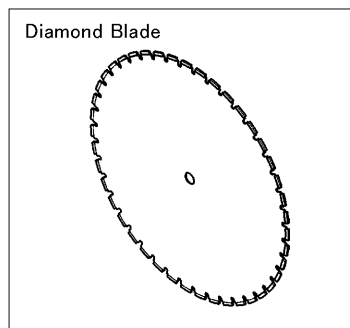

Diamond Blade specially for Wall Cutter (Segment Type)

Diamond Blade for Wall Cutter			
Diameter	Dia. at the tip (mm)	Size of the tip (mm)	Blade Hole Dia. (mm)
30"	784	W5.5 × H11.0	35
	768	W5.5 × H9.0	
40"	1018	W5.0 × H9.0	
	1038	W5.5 × H11.0	

Note) recommended by CONSEC

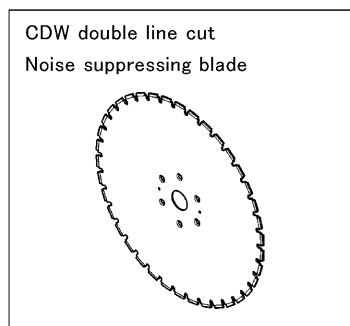

Noise suppressing blade for the use of CDW double line cut

CDW double line cut Noise suppressing blade			
Diameter	Dia. at the tip (mm)	Size of the tip (mm)	Blade Hole Dia. (mm)
20"	518	W4.5 × H9.0	35
22"	568		
24"	618		
26"	668		
30"	768		

Note) Dia. at the tip is the diameter at the edge of Segment Tip.

CDW double line cut flange set

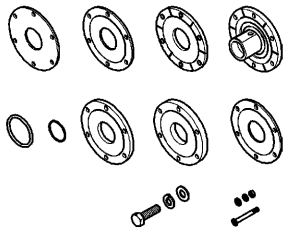

Description	Remark	Qty
Blade retainer	—	1
Spacer	3 mm Black	1
	5 mm	2
	5 mm Groove	2
	7.5 mm Groove	1
	1 0 mm	1
O-ring	P-6 5	1
	S-4 6	1
Hex. bolt (11T)	M1 6 x 5 5	1
Spring washer	1 6	1
Flat washer	1 6	1
Flush bolt	M8 x 7 0	6
Spring washer	8	6
Flat washer	8	6
Hex. nut	M8	6
Instruction manual	—	1

When cutting double lines or cutting at the edge of wall, this set is used by replacing with standard Blade Retainer.

CDW double line cut half cover

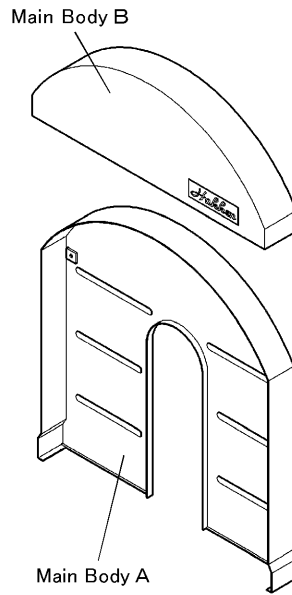

24A
26A
31A

When cutting double lines or cutting at the edge of wall, this half cover is used. There are 24", 26" and 31" types.

CDW double line cut full cover

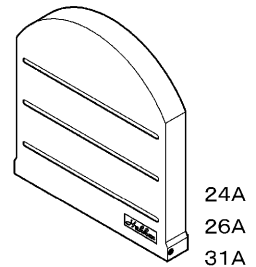

When cutting double lines, this full cover is used. There are 24", 26" and 31" types.

Cut anchor

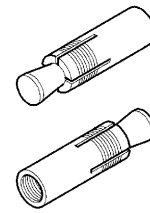

Used to fix Track Rails.

7 . GENERAL DRAWING IN USE AND SPECIFICATIONS

[1] CDW-40AEx for 30" use

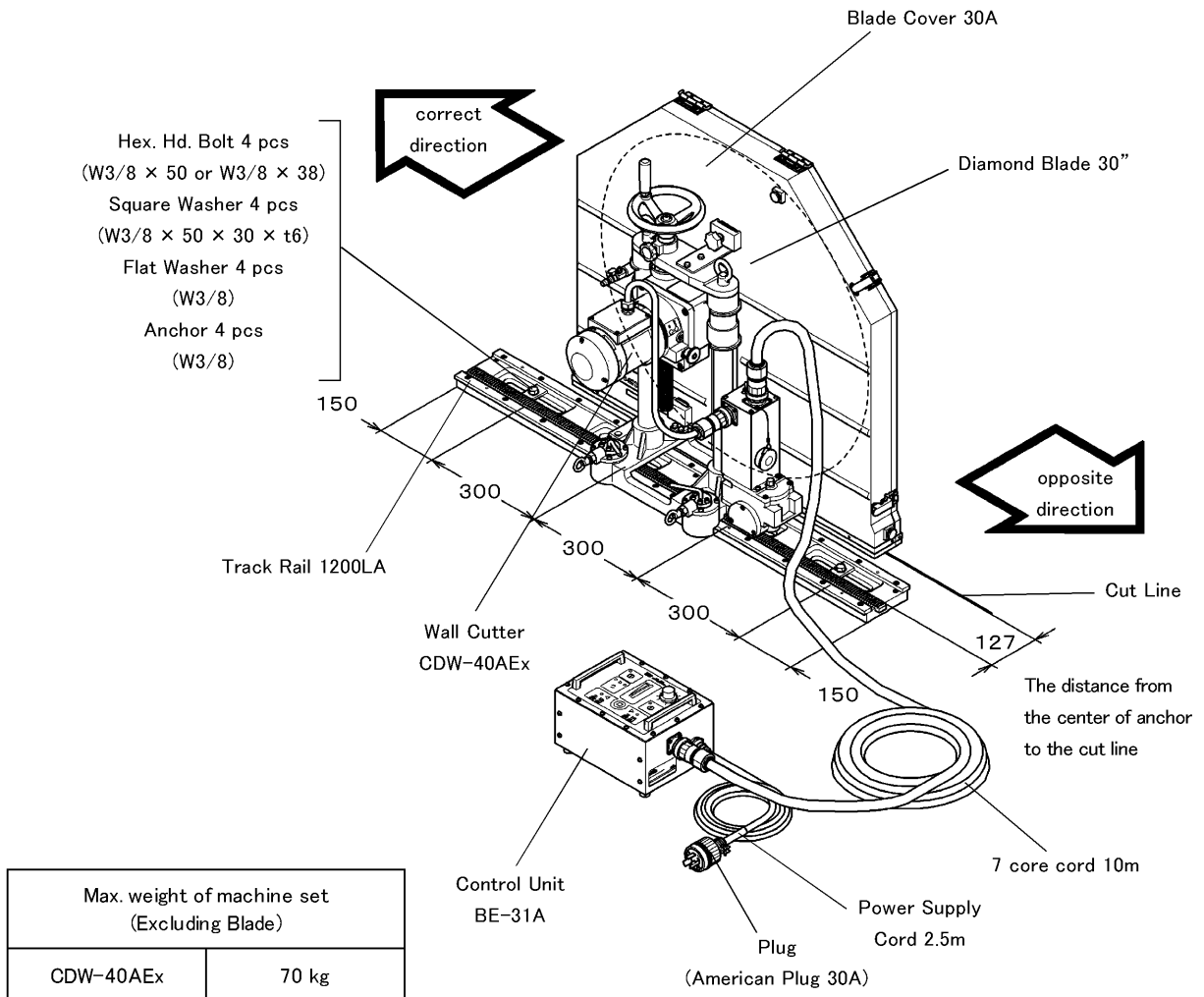

The relationship between the diameter of Blade and Max. Depth and Width of Cut

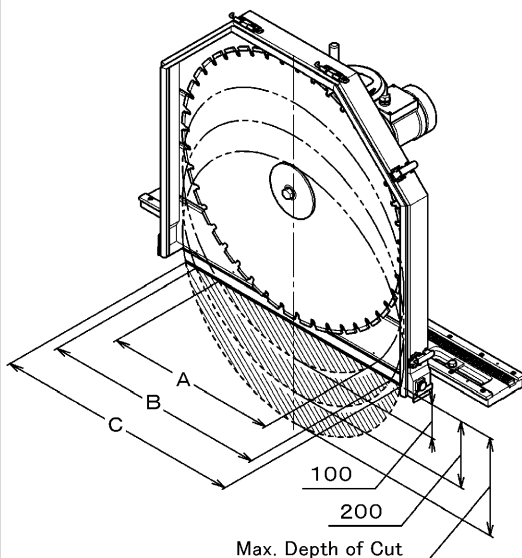

Diameter	Blade	Depth and Width of Cut		
	Dia. at the tip (mm) (Blade Type)	A	B	C (Max. Depth of Cut)
30"	768 (CW-1)	517	674	751 (304.5)
	766 (CW-2)	516	673	749 (303.5)
	768	517	674	751 (304.5)
	784	523	684	768 (312.5)
40"	1018	606	809	1006 (429.5)
	1038	613	819	1026 (439.5)

※ If new blade is used.

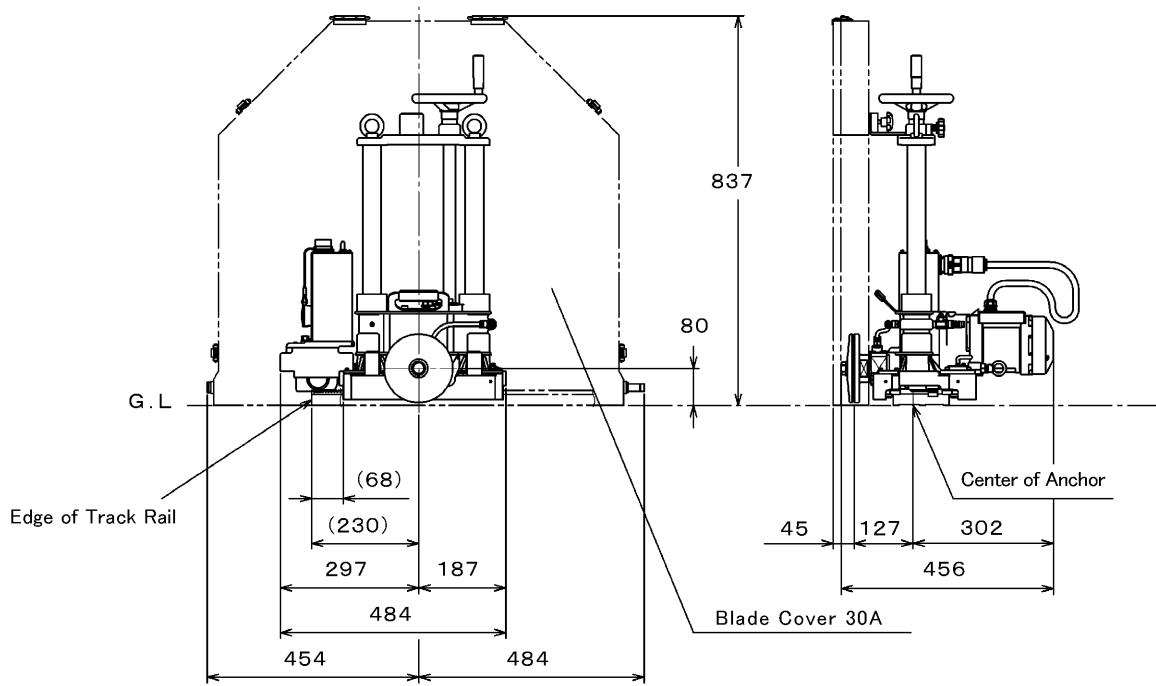

STANDARD SPECIFICATIONS

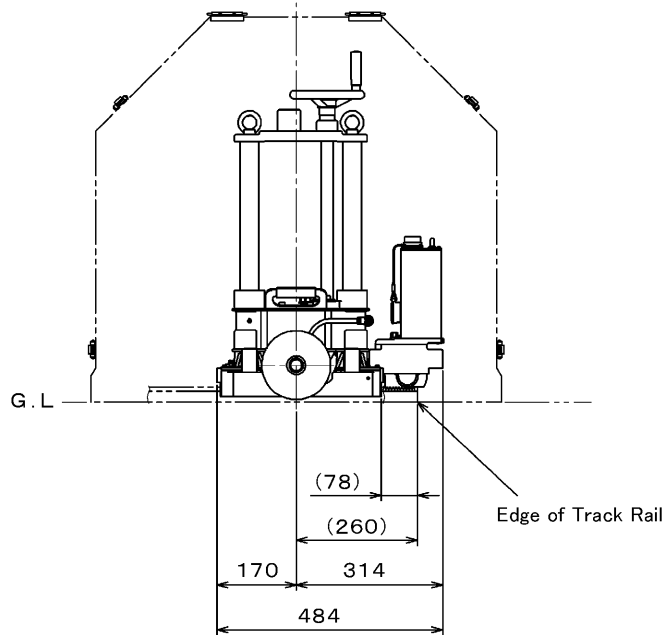

In case the position of Feeding Unit is changed

【2】 Specifications for the use with CDW double line cut attachment

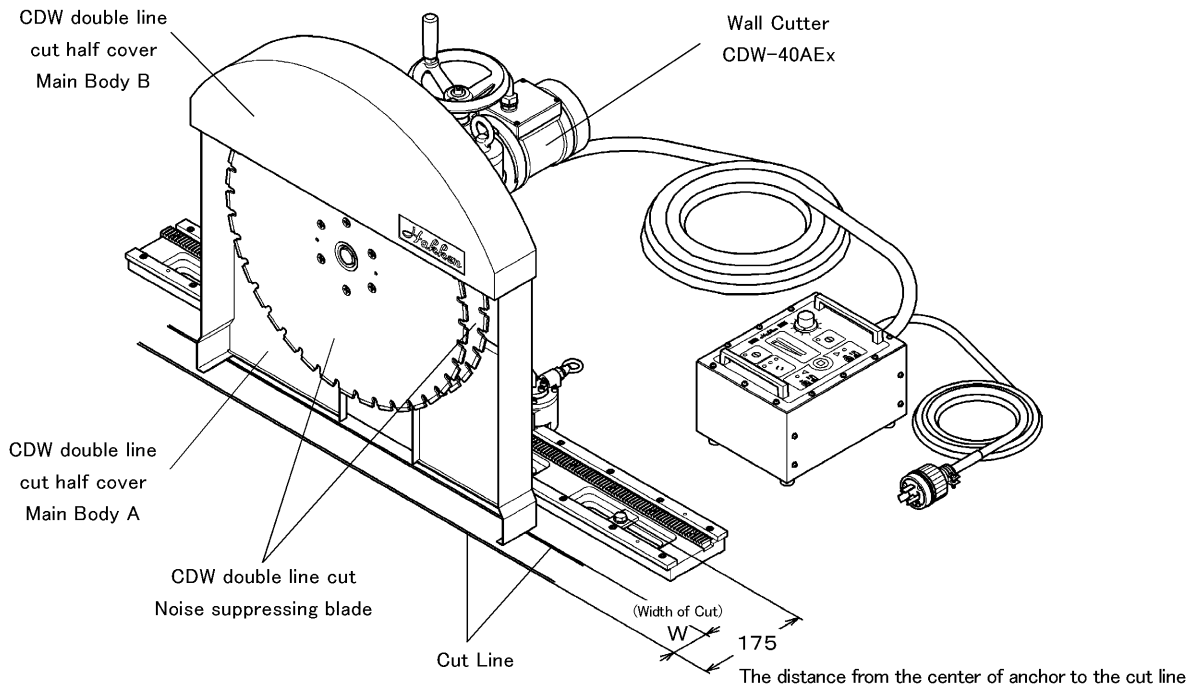

The relationship between the width of cut and a procedure of attaching spacers

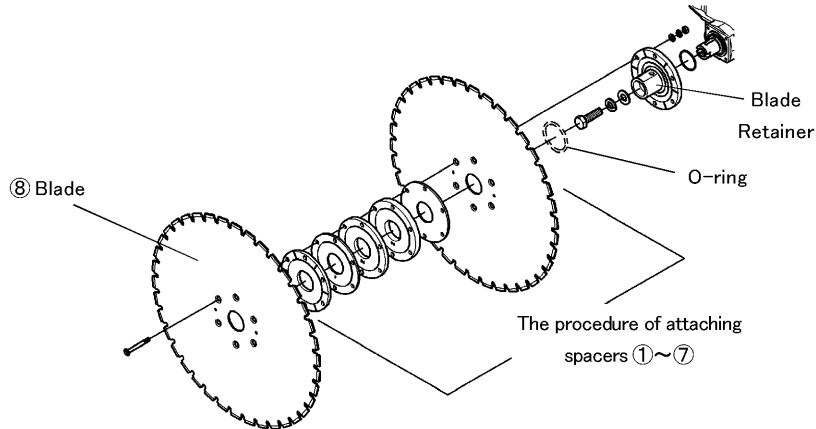

Width of Cut W	The procedure of attaching spacer								
	O-ring	①	②	③	④	⑤	⑥	⑦	⑧
50 mm	without	Blade	5 mm groove	5 mm	10 mm	15 mm	—	7.5 mm groove	Blade
45 mm	with	5 mm groove	Blade	5 mm groove	10 mm	15 mm	—		
40 mm		5 mm	5 mm groove	Blade	5 mm groove	5 mm	15 mm		
35 mm		10 mm	5 mm groove	Blade	5 mm groove	15 mm	—		
30 mm		15 mm	5 mm groove	Blade	5 mm groove	10 mm	—		
25 mm		5 mm	15 mm	5 mm groove	Blade	5 mm groove	5 mm		
20 mm		10 mm	15 mm	5 mm groove	Blade	5 mm groove	—		
Cutting with one Blade only		—	3 mm Black	5 mm	5 mm	10 mm	15 mm	—	

⚠ CAUTION

- To feed water to the surface of cutting blade, the spacer with 5mm groove and 7.5mm groove, which comes into contact with Blade, should be attached so that the groove side comes into contact with Blade.
- To attach Blade Retainer, Ratchet Wrench 24mm is necessary.

8 . OPERATIONAL INSTRUCTIONS FOR CONTROL BOX BE-31A

【1】 Control Panel of Control Box BE-31A(230V type)

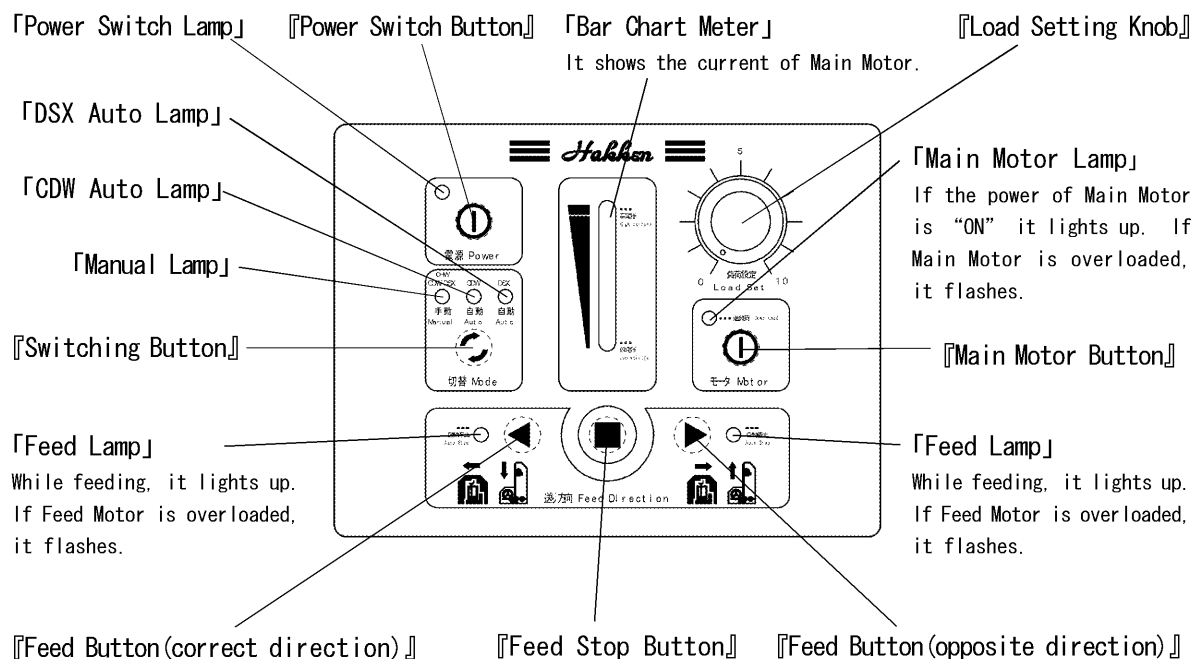

【2】 Operational Instructions for Wall Cutter CDW-40AEx using Control Box BE-31A

⚠ WARNING

1. Control Box BE-31A must be operated by the same operator who uses Wall Cutter.
2. If Control Box BE-31A is operated at a distance from Wall Cutter, make sure the safety at the surrounding area of Wall Cutter before operation.

1. "ON" and "OFF" of Wall Cutter CDW-40AEx Main Motor

- 1) Press the power switch button of Control Box BE-31A and make it "ON". (Power Switch Lamp comes on.)
- 2) Press the main motor button and make it "ON". (Main Motor Lamp comes on.) Main Motor of Wall Cutter slowly starts up. Speed becomes maximum at 2 seconds.

⚠ CAUTION

If Wall Cutter CDW-40AEx is operated by Control Box BE-31A, turn the main motor switch of Wall Cutter "ON" before operation.

- 3) To stop Main Motor, press the main motor button and make it "OFF". (Main Motor Lamp lights off.) Also you can press Power Switch Button to stop Main Motor. (Power Switch Lamp lights off.)

2. Automatic Feeding of Wall Cutter

- 1) Press the power switch button of Control Box BE-31A and make it “ON” (Power Switch Lamp comes on.)
- 2) Press Switching Button and make CDW Auto Lamp “ON” .
- 3) Set the preferred cutting load with the load setting knob.
- 4) Press either Feed Button (correct direction) or Feed Button (opposite direction). Control Box BE-31A will automatically adjust the feeding speed so that the load current of Main Motor is kept constant. (It will automatically adjust for the cutting of no rebar concrete or concrete with steel rebar etc.)
- 5) Looking at the bar chart meter, adjust cutting load with the load setting knob.

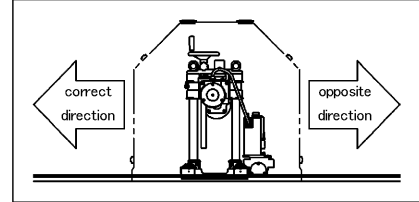

The Position of Load Setting Knob	0	1	2	3	4	5	6	7	8	9	10
Set Current	8	8 . 8	9 . 6	10 . 4	11 . 2	12	12 . 8	13 . 6	14 . 4	15 . 2	16

⚠ CAUTION

1. If the bar chart meter reaches to the top (orange color), Main Motor is overloaded. In this case, lower the setting by Load Setting Knob.
2. If Main Motor is off, regardless of setting the feeding speed becomes maximum.

- 6) To stop the feeding only, press the feed stop button. To stop both the feeding and Main Motor, press Power Switch Button. (Power Switch Lamp lights off.)

3. Manual Feeding of Wall Cutter

- 1) Press the power switch button of Control Box BE-31A.
- 2) Press Switching Button and make Manual Lamp “ON” .
- 3) Set the cutting load at “0” with the load setting knob.
- 4) Press either Feed Button (correct direction) or Feed Button (opposite direction).
- 5) Looking at the bar chart meter, adjust the feeding speed with the load setting knob so that the load current of Main Motor is kept constant. The feeding speed is in proportion to the scale of the load setting knob. At the scale 10, the feeding speed is at maximum. (At the position of 0, the feeding stops and at the position of 10, the feeding speed is at maximum.)
- 6) To stop the feeding only, press the feed stop button. To stop both the feeding and Main Motor, press Power Switch Button. (Power Switch Lamp lights off.)

9 . OPERATIONAL INSTRUCTIONS

【1】 Anchor Fixing

- ① Mark the anchoring position by the scale. Open an anchor hole (Dia. ϕ 14.5mm, Depth 55mm) at the marked position using a hammer drill.
- ② Clean the hole by Dust Blower.
- ③ Insert Anchor (W3/8) into the hole.
- ④ Drive the Anchor (W3/8) securely by Driving Holder and hitting hard by Hammer.

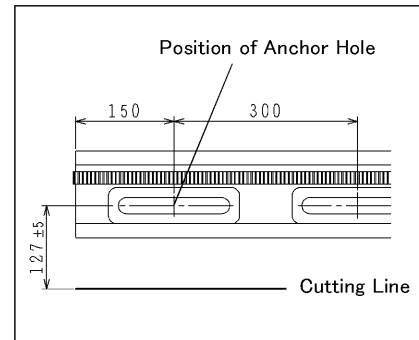

⚠ WARNING

1. For the safety, use 4 positions of anchor fixing per 1 piece of Track Rail 1200LA. Use 2 positions of anchor fixing per 1 piece of Track Rail 600LA. Use 6 positions of anchor fixing per 1 piece of Track Rail 1800LA.
2. Take care so that chips are completely blown out of the hole. Otherwise anchors could come loose.
3. If it is not driven deep enough, the anchor could come loose.
4. Use concrete anchors specified by CONSEC.

【2】 Installation of Wall Cutter

- 1) Temporarily fix Track Rails with Square Washer (W3/8 \times 50 \times 30 \times t6) and Flat Washer (W3/8) and Hex. Hd. Bolt (W3/8 \times 38mm or W3/8 \times 50mm).
- 2) Adjust the position of Track Rails so that the distance from the side of Track Rail to the cutting line becomes 84mm by the scale.
- 3) Adjust the leveling of Track Rails using Hex. Bar Wrench (5mm) up and down. After adjusting it, securely fix Track Rails.

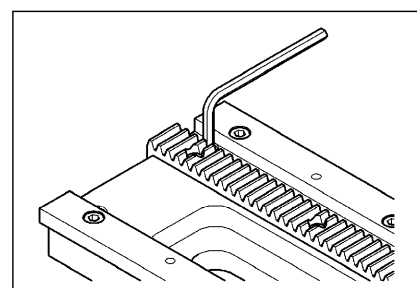
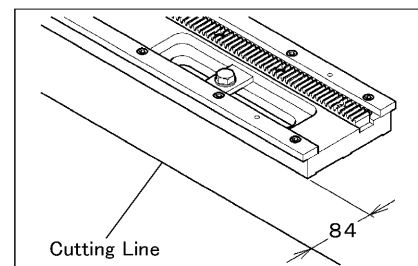
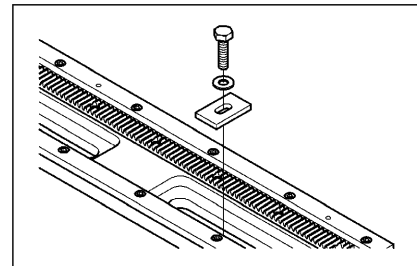

- 4) Pull Eye Nut attached on the base of Wall Cutter and turn Swing Lever to the direction of “Release” .
- 5) Lift Wall Cutter. Engage the roller of the base with the plate of Track Rail at the preferred position and set Wall Cutter on the Track Rail.
- 6) Pull Eye Nut on the base of Wall Cutter and turn Swing Lever to the direction of “Lock” .

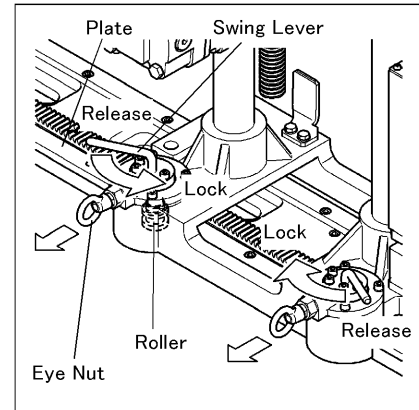

- 7) Make sure that 4 pcs of Roller and the plate of Track Rail are securely engaged and the pin on the tip of Eye Nut has come into the Swing Lever.

⚠ WARNING

1. In case Wall Cutter is used for the horizontal cutting on the wall, mount Wall Cutter by more than two persons. Be careful not to drop Wall Cutter.
2. If Swing Lever is not correctly turned to the direction of “Lock” , the roller could come out of the plate of Track Rail. This is very dangerous!

【3】 Setting Speed of Geared Motor

- ⊙ Set the speed of Geared Motor at LOW by pulling Speed Change Knob.

Depends on the diameter of Blade or the object to be cut, the speed of Geared Motor is set at HI. Choose the speed according to the conditions.

⚠ CAUTION

If Speed Change Knob is difficult to move, by gradually moving Blade Retainer, pull Speed Change Knob.

【4】 Installation of Diamond Blade

- 1) Turn Cutting Handle anticlockwise and move up Geared Motor upper most position. Fasten Knob Bolt to fix it.
- 2) Install the Diamond Blade. Please see INSTALLATION AND DETACHMENT OF DIAMOND BLADE in page 23 in detail.

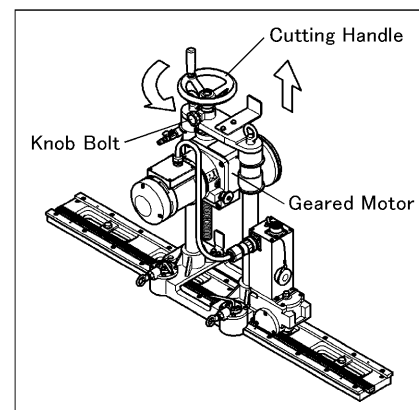

【5】 Connection of Control Box BE-31A

- 1) Switch the main motor switch of Wall Cutter “OFF” .

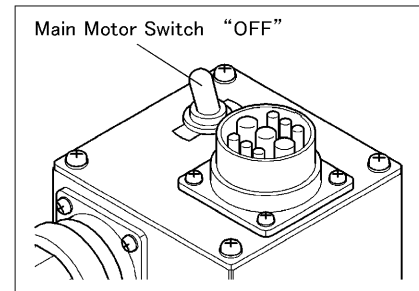

- 2) Connect Wall Cutter CDW-40AEx and Control Box BE-31A by 7 core cord 10m.

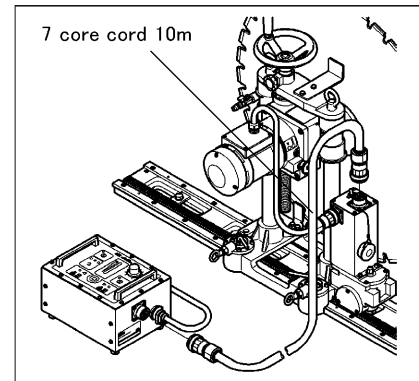

- 3) Insert the plug of Control Box BE-31A in the power socket.

【6】 Connecting Track Rails

- 1) Install concrete anchors in like manner described in 【1】 Anchor Fixing in page 15.

- 2) Engage the rack gear of Track Rail and the rack gear of next Track Rail and make the side face of each Track Rail closely in contact. Fix Track Rails with Square Washer (W3/8 × 50 × 30 × t6) and Flat Washer (W3/8) and Hex. Hd. Bolt (W3/8 × 38mm or W3/8 × 50mm).

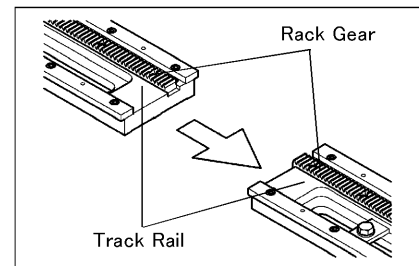

⚠ WARNING

In case Wall Cutter is used for the horizontal cutting and Track Rails are installed on the wall, be careful not to drop Track Rails.

- 3) In case the matching of each plate of connecting Track Rails is not flat or there is still a space between Track Rails and the surface to be cut, adjust the leveling of Track Rails using Hex. Bar Wrench (5mm).

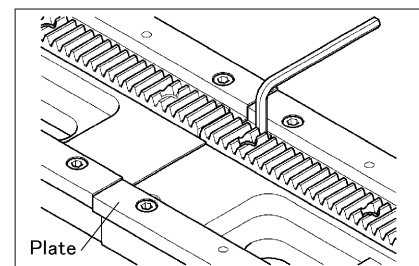

- 4) Adjust the position of Track Rails so that the distance from the side of Track Rail to the cutting line becomes 84mm by the scale.

⚠ CAUTION

Do not hit Track Rails by such as hammer.

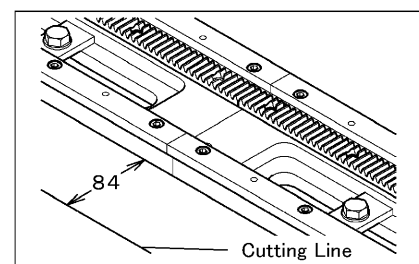

- 5) Run Wall Cutter on the Track Rail without turning Main Motor Switch “ON” to make sure if Diamond Blade is in alignment or not. If not, make a small adjustment of Track Rails.

⚠ WARNING
Do not rotate Diamond Blade. Make sure Main Motor Switch is “OFF” .

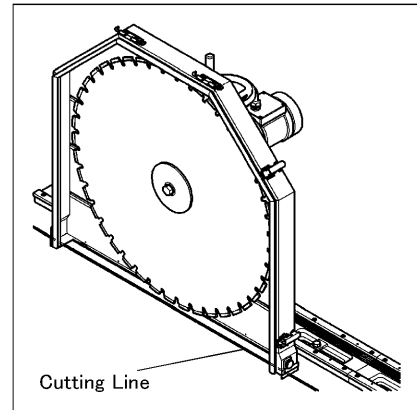

- 6) Securely fasten all Hex. Hd. Bolt on the Track Rail by Ratchet Wrench.

【7】 Installation of Blade Cover

- 1) Match Blade Cover Main Body against the front face of Blade Cover. Fix them by separating retractable hinge and clip lock.
- 2) Attach Blade Cover to Wall Cutter and fix it by fastening Knob Bolt.

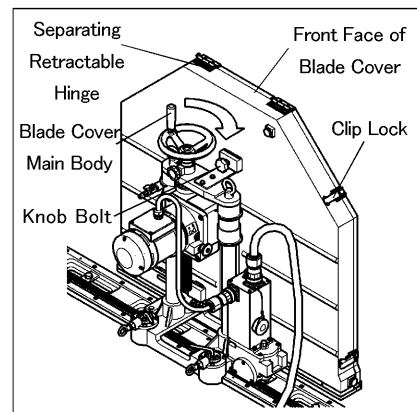

- 3) Move the position of drain port as necessary, connect one end of drain hose with drain port and place the other end of drain hose into a bucket.

【8】 Preparation of feeding water

- ⊙ Close Water Cock. Connect Feed Water Coupler on it or Feed Water Hose by fixing by hose band on it.

【9】 Treatment of splashing water

1. Treatment of splashing water based on the cutting site

- ⊙ Cutting water splashes. Take measures such as surrounding the scene by sheet.

⚠ WARNING
Take measures also at the opposite side of wall where to be cut.

2. Treatment of splashing water for the feeding motor

- ⊙ As feeding water, rotate Diamond Blade. If the cutting water splashes over the feeding motor, take measures for it. If no measure can be taken, stop operation.

⚠ WARNING
If Wall Cutter is used on the wall to cut vertically up and down and the feeding motor comes down on the side of Wall Cutter, particularly be careful for it.

【10】 Cutting Operation for Automatic Feeding

⚠ WARNING

During operation if abnormality occurs on the wall cutter, turn the power switch button of Control Box BE-31A “OFF” and stop operation.

- 1) Open the faucet of running water and gradually open water cock. Adjust the amount of water.

⚠ CAUTION

Water must be supplied around 3 liters per minute.

- 2) Turn 「ON」 the main motor switch of wall cutter.

⚠ CAUTION

Make sure that the power switch of Automatic Feeding System of BE-31A is 「OFF」 .

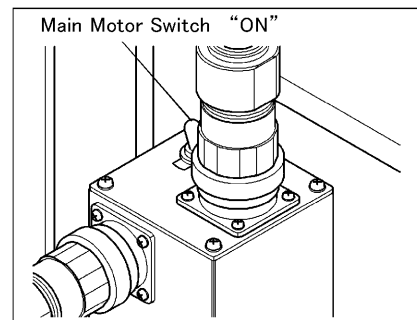

- 3) Set the preferred load setting volume of the Automatic Feeding System BE-31A, and press the power button 「ON」 .

⚠ CAUTION

In case that the upper lamp (orange color) or the lower lamp (green color) on the bar chart meter flash, and you can not operate it by pressing other buttons, it could be that the power voltage has problems. Please refer to TROUBLESHOOTING DURING OPERATION in this manual.

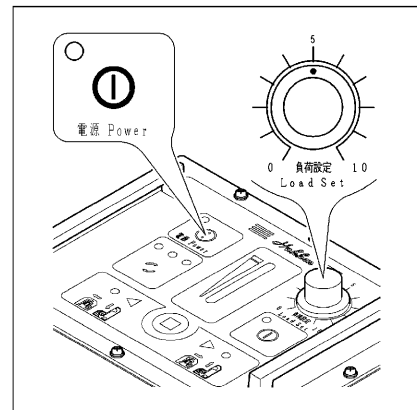

- 4) Press 『Transfer Button』 of Automatic Feeding System BE-31A, light 「CDW Auto Lump」 on, and press 『Motor Button』 「ON」 . Then, rotate the diamond blade. When rotating the diamond blade, make sure that turn 「ON」 the motor button of Automatic Feeding System BE-31A, then operate.

⚠ CAUTION

In case that the main motor switch of the main body of the wall cutter is 「ON」 and rotate the diamond blade, the life of the clutch will be shortened by slipping the clutch of the geared motor.

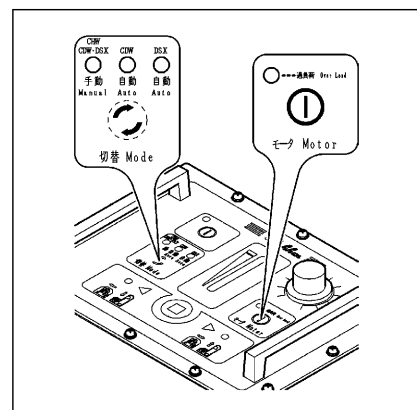

- 5) Start cutting the objects with the diamond blade by using the cutting handle, and tighten the knob bolt, then fix the cutting handle.

- Cutting depth at a time should be less than 100 mm.
(The diamond blade moves 5 mm per one rotation of the cutting handle)

 CAUTION
<p>In case of that you cut deeply at a time, not only a burden to the machine will be increased, but also the cutting speed will slow down. Therefore, avoid cutting deeply by force.</p>

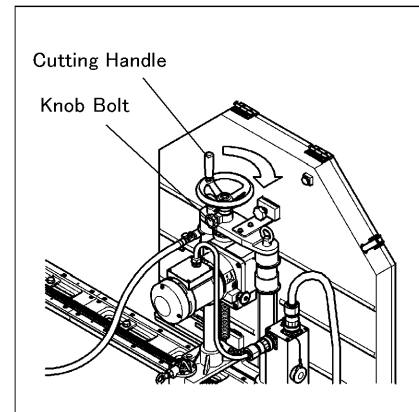

- 6) Press the feed button (forward direction) or the feed button (opposite direction) of Automatic Feeding System BE-31A, and operate the cutting.

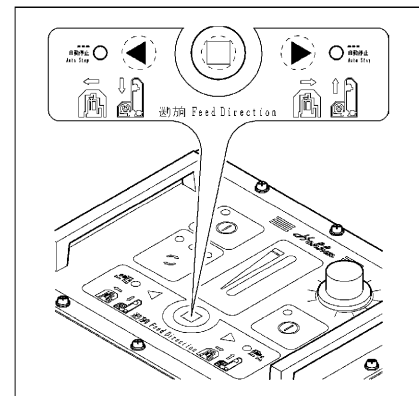

- 7) Adjust the load setting with looking at the bar chart meter by controlling the load setting volume by considering the sound of the main motor, the rotation condition of the diamond blade and the rotation speed.

- 8) After cutting the necessary distance, press the feed stop button and stop the operation.

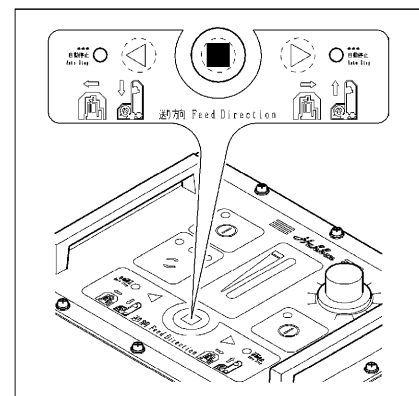

- 9) Repeat the operation from 5) to 8), then continue the cutting operation until reaching to the necessary depth.
- 10) Step cut (applying the diamond blade which is more than 30")
- ① Remove the blade cover and the diamond blade.
 - ② Insert the diamond blade which is more than 30" into the cutting slot.
 - ③ Install the diamond blade in that the diamond blade must be installed into the slot. For more details, please refer to INSTALLATION AND DETACHMENT OF DIAMOND BLADE in the page 23.

- ④ Install the appropriate size of the blade cover which fits the diameter of the diamond blade.

⚠ WARNING

When exchanging the diamond blade, make sure that the main motor switch of wall cutter is "OFF". Then, plug off Automatic Feeding System BE-31A from the power supply.

- 11) After completing the cutting operation, turn the cutting handle, and lift the diamond blade up until the diamond blade shows up from the cutting object.
- 12) Turn off the main motor switch of the wall cutter, then stop supplying the water.
- 13)) Press the power button "OFF", then, stop the all of operation.

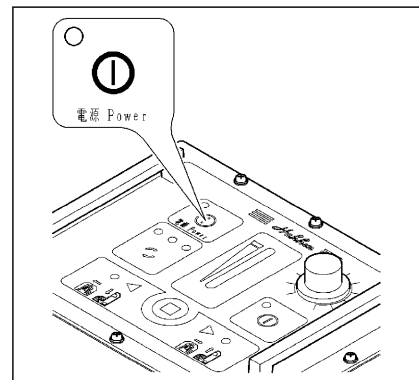

【11】 Detachment of Wall Cutter

- 1) Plug off Control Box BE-31A from the power socket.
- 2) Remove the Blade Cover.

⚠ CAUTION

Be careful that the cutting water and sludge remained inside do not come out of Blade Cover.

- 3) Detach the Diamond Blade. Please see INSTALLATION AND DETACHMENT OF DIAMOND BLADE in page 23 in detail.
- 4) Disconnect 7 core cord 10m.

⚠ CAUTION

1. Before disconnecting 7 core cord 10m, wipe off the water on and around the Receptacle.
2. Do not disconnect 7 core cord 10m by yanking the cord.
3. After disconnecting 7 core cord 10m, always use the Cap on the Receptacle of Wall Cutter.

- 7) Remove Track Rail.

⚠ WARNING

If CDW -40AE is set to the wall, remove it with more than two person for sure, and be careful not to drop the Track Rails.

- 8) Clean the cutting areas.

10 . SEPARATION AND ASSEMBLING OF WALL CUTTER

⚠ WARNING

When separating or assembling Wall Cutter, to avoid an accident, plug off Control Box BE-31A from the power socket.

【1】 Separation of Wall Cutter

- 1) Disconnect one-touch plug of the Main Motor.
- 2) Using bar such as Ratchet Wrench, turn 2 pcs of Eye Bolt and remove them.
- 3) Turn Cutting Handle to move up Geared Motor to the upper most position. Turn further Cutting Handle and remove Cutting Handle and Top Plate.
- 4) Remove Geared Motor from Guide Rod.

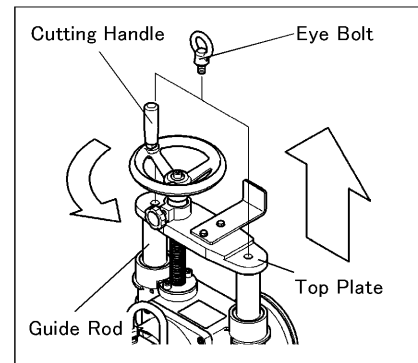

⚠ WARNING

When separating Wall Cutter, unless the Base is fixed, a person could get injured when removing Geared Motor from Guide Rod.

【2】 Assembling of Wall Cutter

- © As for assembling of Wall Cutter, follow above procedures in the reversed order.

⚠ CAUTION

1. Make sure that the grease is applied to the inside of Guide Rod entry of Geared Motor. If the amount of grease is not enough, add more grease to it.
2. If Wall Cutter is separated piece by piece for a long time, make sure that the dust or debris does not adhere to the sliding part.

1 1 . INSTALLATION AND DETACHMENT OF DIAMOND BLADE

⚠ WARNING

When installing or detaching Diamond Blade, to avoid an accident, plug off Control Box BE-31A from the power socket.

【1】 Installation of Diamond Blade

1. In case water is fed on both sides of Diamond Blade.

- 1) Detach Hex. Hd. Bolt, Flat Washer, Blade Retainer by Single-ended Wrench (24mm).
- 2) Remove O-Ring and store it.
- 3) Set the Diamond Blade.
- 4) Then set the Blade Retainer, Flat Washer and Hex. Hd. Bolt back and tighten the bolt with the Single-ended Wrench (24mm) securely.

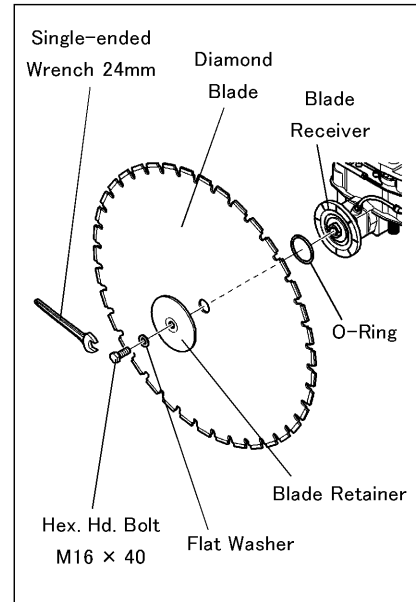

2. In case water is fed only on the side of Blade Retainer.

- 1) Detach Hex. Hd. Bolt, Flat Washer, Blade Retainer by Single-ended Wrench (24mm).
- 2) Attach O-Ring on Blade Receiver.
- 3) Set the Diamond Blade.
- 4) Then set the Blade Retainer, Flat Washer and Hex. Hd. Bolt back and tighten the bolt with the Single-ended Wrench (24mm) securely.

⚠ WARNING

If Wall Cutter is used on the wall to cut horizontally and the main motor is on the down side of Wall Cutter, always attach O-Ring to prevent the splashing water from entering the main motor.

⚠ CAUTION

If Wall Cutter is used for the horizontal cut and the main motor is on the down side of Wall Cutter, water is fed only on one side of Diamond Blade. In this case the efficiency of cooling decreases, therefore do not force Wall Cutter. If Wall Cutter is forced as same as the case water is fed on both sides of Diamond Blade, Diamond Blade could be deformed.

【2】 Detachment of Diamond Blade

© As for Detachment of Diamond Blade, follow above procedures in the reversed order.

12 .TROUBLESHOOTING DURING OPERATION

【1】 The troubles could occur during operation and their solution.

If a problem becomes apparent during operation, immediately stop the operation to ensure that the equipment is safe, and investigate using the following table.

Problem	Cause	Solution
The top portion of the bar chart meter (orange color) of Control Box BE-31A flashes.	The power supply voltage is too high. (above 260V)	Connect with the correct power supply source.
The bottom portion of the bar chart meter (green color) of Control Box BE-31A flashes.	The power supply voltage is too low. (below 195V)	Connect with the correct power supply source. If the abnormal power supply voltage is only temporary, wait until it returns to normal range. Reset the unit by pressing the Power Switch Button.
Main Motor Lamp of Control Box BE-31A flashes.	Main Motor is overloaded. Overload protection is working.	Press Main Motor Button or Power Switch Button to release the flashing. Solve the cause of overloading.
Feed Lamp of Control Box BE-31A flashes.	Feed Motor is overloaded. Overload protection is working.	Press Feed Stop Button or Power Switch Button to release the flashing. Solve the cause of overloading.
Wall Cutter stopped.	Wall Cutter and Blade Cover are hitting the object.	Remove the object.
	Long stud bolt is used to fix Track Rail and the Base of Wall Cutter is hitting the long stud bolt.	Replace it with specified Hex. Hd. Bolt or fix it again so that the Base of Wall Cutter will not hit it.
	The dust or debris are accumulated on the roller or rack gear.	Clean it up or Repair it.
	The rack gear is damaged.	Repair it.
	The sliding part of Track Rail is deformed.	Repair it.
Although Feed Button of Control Box BE-31A is pressed, Wall Cutter does not run.	Feed Gear Box is damaged.	Repair it.
	Feed Motor is broken.	Repair it.
	The wire inside of 7 core cord 10m is broken.	Repair it.
Cutting Handle can not be turned.	Knob Bolt is fastened.	
	The dust or debris is adhered to the sliding part of Feed Screw.	Clean Feed Screw up. Apply the grease to it.
Cutting speed is slow.	Diamond Blade is cutting the steel bar.	Keep cutting trying not to force it too much.
	Segment tips of Diamond Blade are worn out.	Replace it with new one.
	Cutting performance is not good.	Consult with sales dealer.
Vibration of Wall Cutter is too much.	Installation of Track Rails is not correct.	Install Track Rails again.
	Diamond Blade is deformed.	Repair it.
	Main Shaft Geared Motor is bent. It is out of alignment.	Repair it.
Diamond Blade is locked.	Chip of steel bar or debris of mixed stone in the concrete is jammed between Diamond Blade and the surface of cut groove.	Refer to「An example of solving method when Diamond Blade is locked」in this manual.
	Both sides of Segment tips of Diamond Blade are worn out and Segment tips and Blade Base are flat.	Replace it with new one.

【2】 An example of solving method when Diamond Blade is locked

- 1) Press the power switch button and make it “OFF” . Plug off Control Box BE-31A from the power socket. Remove the Blade Cover.
- 2) Turn Cutting Handle to move Diamond Blade up and down or turn Hex. Hd. Shaft by Speeder 204 etc. to move Wall Cutter back and forth, so that it becomes easier to pull up Diamond Blade out of cut groove.

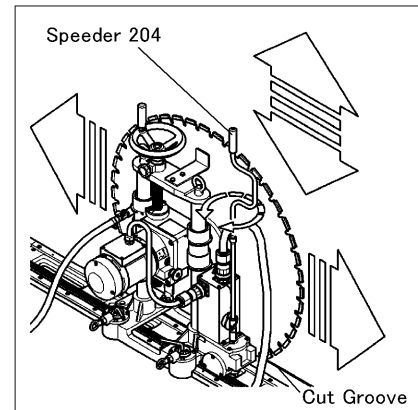

⚠ CAUTION

When moving Diamond Blade up and down or moving Wall Cutter back and forth, do not force it too much. If it is forced too much, the segment tips of Diamond Blade could drop out.

- 3) Remove the cause of locking (Chip of steel bar or debris of mixed stone) of Diamond Blade as much as possible.
- 4) By repeating the procedure 2) and 3), gradually pull up Diamond Blade out of cut groove.

13 . MAINTENANCE AND SERVICING

【1】 Maintenance

- 1) Clean the surface of Wall Cutter.
- 2) After entire operation is over, run Main Motor with non-load and drive dirt and dust out of Motor interior.
- 3) Clean Guide Rod in particular.
- 4) Clean Roller.
- 5) Apply grease to Feed Screw.
- 6) Apply oil to Level Bolt of Track Rail.
- 7) Clean Blade Cover after removing Front Face of Blade Cover. Clean up the clogging up of drain port if necessary.

【2】 Regular Inspection, Servicing

- Ⓞ Inspect whether Wall Cutter, Blade Cover, Track Rail and Diamond Blade have cracks or fractures. Inspect whether the sliding portion of Wall Cutter and Track Rail have looseness or not. Also inspect whether the coating part of Power Supply Cord and Plug have cracks or fractures.

If any abnormality is found, contact your nearest dealer or Consec' s distributor.

【3】 Repairs

- ⊙ If Clutch becomes easy to slip due to wearing out of Friction Plate, contact your nearest dealer or Consec' s distributor and ask re-adjustment of the clutch.
- ⊙ The unit is manufactured to precise dimensions. If it does not operate properly, contact your nearest dealer or Consec' s distributor. Do not repair it yourself.
- ⊙ Do not hesitate to contact your nearest dealer or Consec' s distributor if you have any questions regarding use or handling of the unit.

【4】 Regular Servicing

1. Checking of Carbon Brush

1) How to check

- Remove three of bearing cap attaching screw (hex. socket bolt M6 × 35) by using hex. bar wrench 5 mm, and remove bearing cap. (In case that it is difficult to remove it, install two flathead screwdrivers both side of the gaps and move the flathead screwdriver up and down so that it will be easier to remove the bearing cap.) then, remove carbon brush. After the inspection, drive bearing cap tightly.

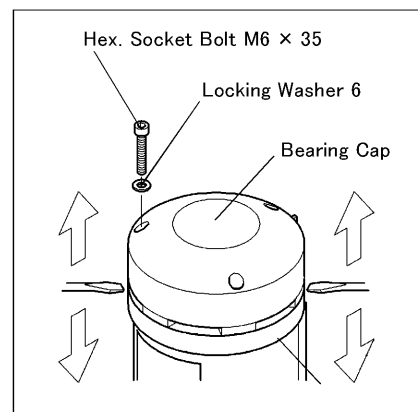

2) Replacement

- The excessive abrasion of carbon brushes causes motor failure. Check regularly, when they are worn up to the wear limit line (10mm), replace with new ones.
- Keep them clean for free sliding in brush holder.

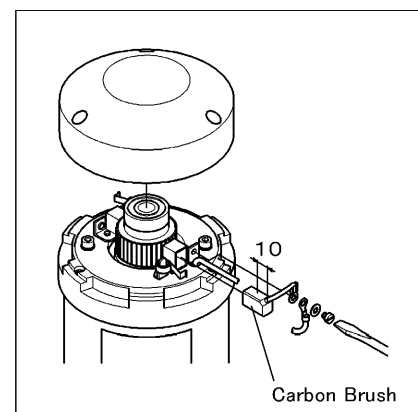

⚠ CAUTION

Insist on identical carbon brushes in replacement.

2. Checking of attaching screws

- ⊙ Check every attaching screws for loosening periodically. If found loose, tighten it.

14 . WARRANTY

We will guarantee the HAKKEN core drilling machine for 6 months from the date of delivery. During this period we will rectify material and production defects free of charge. We are not responsible for any other damage direct nor indirect other than this. This warranty does not cover normal wear and tear, overloading, non-compliance with the operating instructions and intervention by unauthorized persons or the use of parts from other companies.

M E M O

M E M O



CONSEC CORPORATION

Main office : 4-6-8 Shoko Center Nishi-ku Hiroshima 733-0833 Japan
International Department : 4-6-8 Shoko Center Nishi-ku Hiroshima 733-0833 Japan
Phone : 81-82-276-3231 Fax : 81-82-276-3239

E1031-0/CDW-40AEx